

Introduction

Roboteq's AX1500, AX2500 and AX3500 family of motor controllers can be modified so that both output channels can drive a single load with twice the current. The modification causes the MOSFETs of each channel to switch in a perfectly synchronized manner from one another. This synchronization is required in order to ensure that the high and low side drivers of each channel's bridge switch identically. Once synchronized, the outputs of each channel can be wired together and connected to each of the motor wires.

Making the Modification

AX2550 AX3500

The modification requires that a drop of solder be applied on a specific location on the controller's PCB, effectively acting as an electrical jumper. This technique, rather than a typical plug-in jumper, is used because of its highest reliability in a shock and vibration environment.

To access the PCB, the AX2550/2850 requires that the case be opened as shown in the figure below.

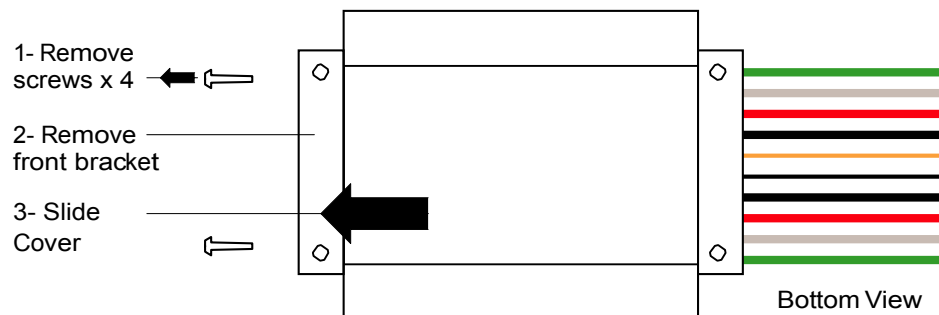

FIGURE 1. Opening the case

Locate the 4 solder jumpers on the PCB around the middle of the board. Place a drop of solder on the right-most one as shown on the figure below. Leave all other jumpers as they are.

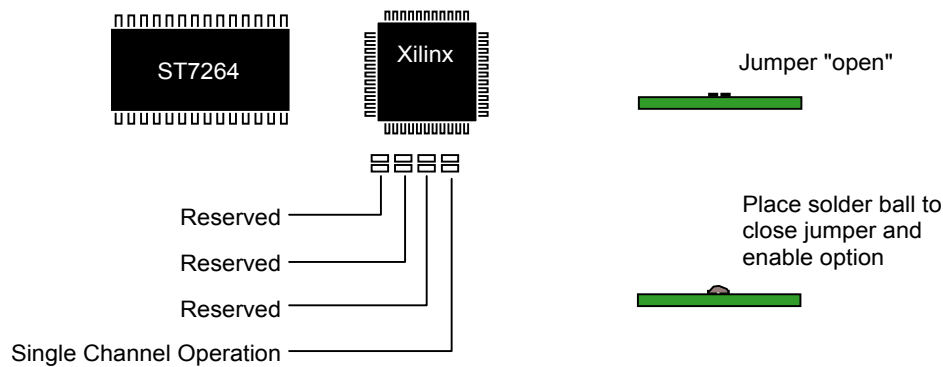

FIGURE 2. AX2550 AX3500 jumper location

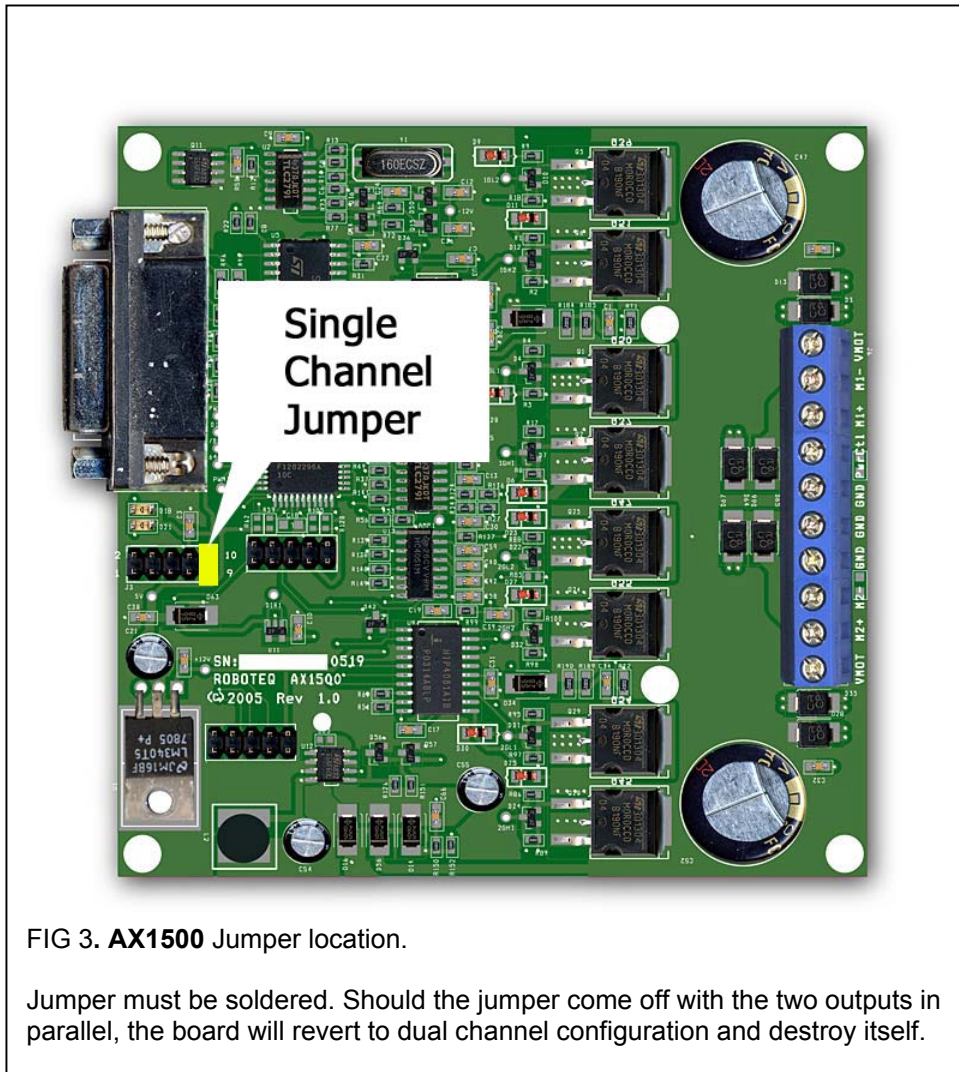
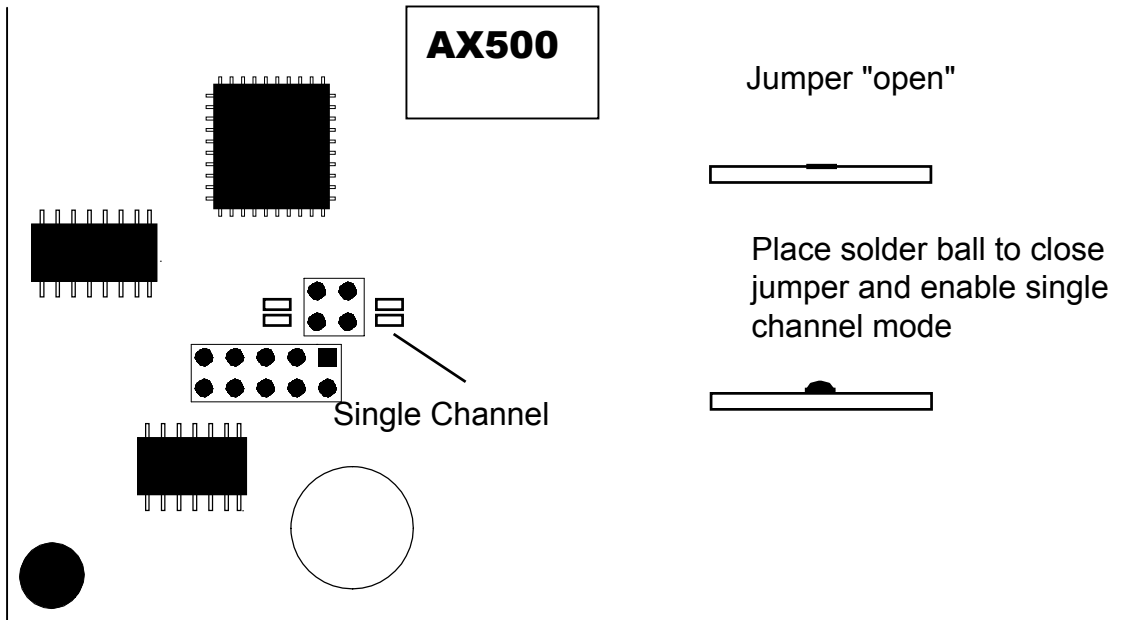

FIG 3. AX1500 Jumper location.

Jumper must be soldered. Should the jumper come off with the two outputs in parallel, the board will revert to dual channel configuration and destroy itself.

Wiring for Single Channel Operation

After the jumper solder is made, it the controller can be safely connected to the motor and battery as shown in the figure below.

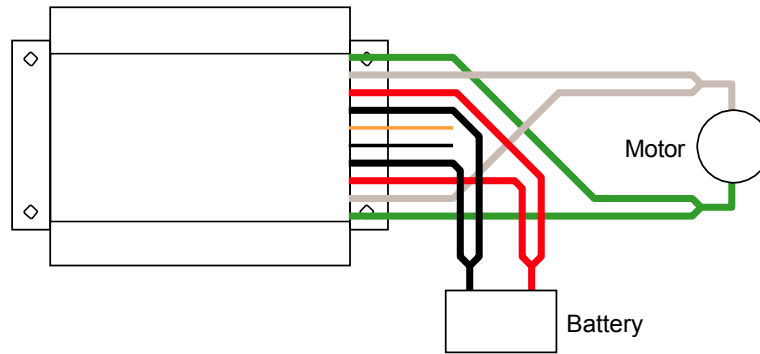

FIGURE 3. Single Channel Wiring

On the AX1500 AX3500, connect each pair of identically labeled contacts together (VMOT, GND). Connect M1+ to M2+ and to the motor's first wire. Connect M1- to M2- and to the motor's second wire.

Important Warning

Do not wire the motor for Single Channel Operation without the jumper modification. Certain destruction will occur.

Software Consideration

No new software needs to be downloaded to the controller. The controller automatically detects the presence of the jumper and switches to Single Channel Operation

Controllers modified for Single Channel Operation respond to commands sent to Channel 1.

The Roborun PC utility will automatically detects that the controller is set for Single Channel Operation and modify some of the setup screens accordingly. The Amps Limit slider will show doubled values. When exercising the controller with the Run tab, the screen still shows each of the channel's individual Amps. The total Amps flowing into the load is the sum of each of the channel's reported Amps.

The controller still supports the mixed mode (for tank-like steering) while in single channel mode. This requires that two controllers are used (one for each motor), and that each be fed the same RC or Analog signals and that both controller be configured for Mixed Mode Operation. When setting each controller with Roborun, configure each controller for Mixed Mode Operation. For each controller, select whether it is driving Motor 1 or Motor 2 (this option only appears if a Single Channel controller is detected).

Reverting to Dual Channel

The conversion to Single channel is reversible and the controller can be brought back to Dual channel. First separate the motor wires should they still be connected in parallel for single motor operation, then remove the jumper and restore by Roborun the desired Dual Channel configuration. No other operation is necessary.